

The Zach West Electrolyser

The Zach West Electrolyser. Zach West of the USA has produced an electrolyser for his motorcycle. Zach's 250 cc motorcycle can run on the output of his electrolyser and Zach estimates the output as being 17 litres per minute of hydroxy gas.

Shigeta Hasebe designed, built, tested and patented a spiral DC electrolyser. His bench tests show that he was achieving ten times the maximum rate that Faraday considered possible. To be perfectly fair, Shigeta used two powerful magnets in addition to the DC current so his power input was somewhat higher than Faraday's. Interestingly, Shigeta was disappointed with his results as his theory indicated that he should be getting twenty times the Faraday maximum. In passing, Bob Boyce regularly achieves more than double the Faraday "maximum" using straight DC power and no magnets.

Shigeta's electrodes are arranged like this:

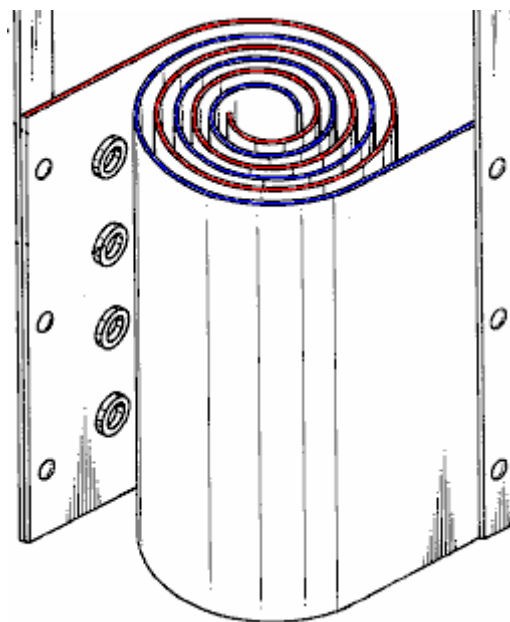

A spiral shape like this is very difficult to produce accurately in stiff metal, but a fairly similar electrode shape can be produced with the help of a length of plastic pipe. This is a description of an electrolyser design by Zach West and which is neither a difficult or particularly expensive device to build. Unlike Shigeta's design, Zach's electrodes are a helix shape where the gap between the coiled electrodes remains the same, unlike a spiral where the gap decreases progressively as the centre is approached.

Please note that this document is intended for information purposes only and is not intended to be instructions for constructing a unit of this nature. Should you decide to do so contrary to the intentions of this document, then you do so entirely at your own risk, and no responsibility whatsoever for your actions rests with anyone connected with the production or display of this material. Anything which you decide to do is entirely your own responsibility, and you should be aware that this device is not a toy, and the gases produced by electrolysis are highly dangerous and explosive.

In broad outline, Zach's electrolyser is fed water from a water tank to keep it topped up. The electrolyser contains several pairs of electrodes which split the water into hydrogen and oxygen when fed with electrical signals from the electronics, which is powered by the battery system of the motorcycle. The gas produced by the electrolyser is fed to a dual-purpose container, which prevents any accidental igniting of the gases from travelling back to the electrolyser (a "bubbler") and which removes most of the oxygen from the gas feed to the engine (a "separator").

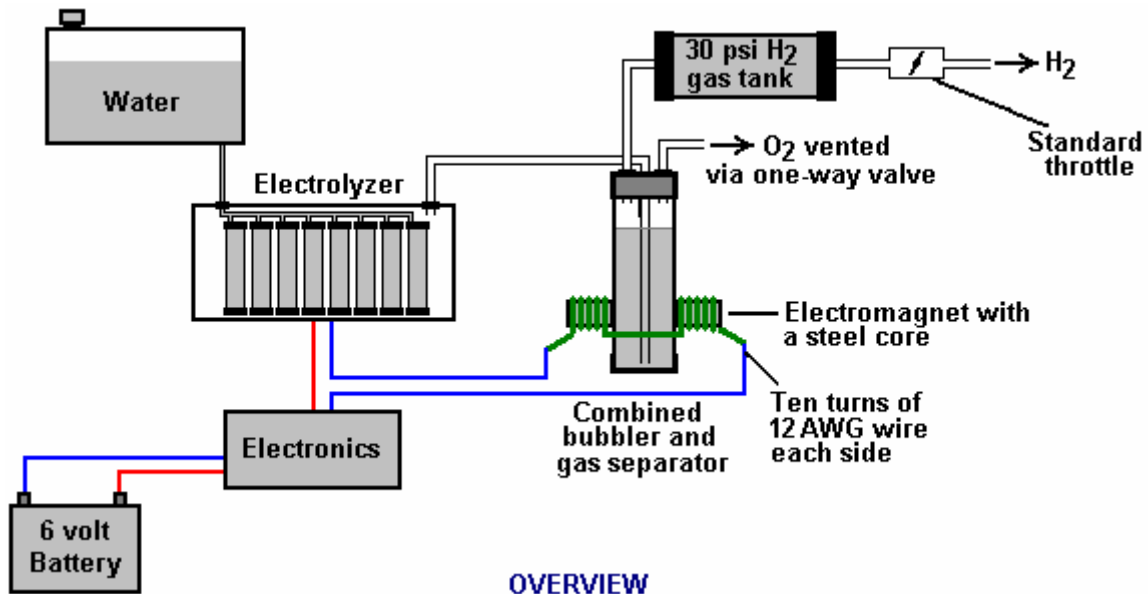

There are some unusual design details which need to be explained. Firstly, the hydrogen gas output from the electrolyser is not fed directly to the engine but instead it goes to a pressure tank which is allowed to build up to thirty pounds per square inch before the engine is started. The gas in the pressure tank having passed through the bubbler, will have water vapour in addition to the hydrogen, and that water vapour is beneficial to the operation of the engine, turning into flash-steam during the power stroke. The majority of the oxygen produced by the electrolysis is vented away through a 30 psi one-way valve which is included to keep the pressure inside the bubbler (and the electrolyser) at the 30 psi level.

This has an additional advantage in that it allows an ultra-simple water top-up system. This water supply system operates by having an air-tight supply tank positioned at a higher level than the electrolyser. A small diameter (1/4") plastic tube from the supply tank feeds through the top of the electrolyser and straight down, terminating at exactly the electrolyte surface level wanted in each of the electrolyser tubes. When the electrolysis lowers the electrolyte level below the bottom of the pipe, a bubbles of gas pass up the tube allowing some water to flow from the tank to raise the electrolyte surface level back to its design position. This is a very neat passive system needing no moving parts, electrical supply or electronics but yet one which accurately controls the electrolyte level. One essential point is that the water tank needs to be rigid so that it will not flex and the filler cap needs to be air-tight to prevent the entire tank discharging into the electrolyser. Another point to remember when topping up the water tank is that the tank contains a mix of air and hydroxy gas above the water surface and not plain air.

Now, to cover the design in more detail. The electrolyser contains eight pairs of electrodes. These electrode pairs are coiled around in "swiss-roll" style and inserted into a length of 2 inch (50 mm) diameter plastic pipe, ten inches (250 mm) tall. The electrodes are each made from a 10 inch (250 mm) by 5 inch (125 mm) of 316L-grade stainless steel shimstock which is easy to cut and work.

Each electrode sheet is cleaned carefully, and wearing rubber gloves, cross-scored using coarse sandpaper in order to produce a very large number of microscopic mountain peaks on the surface of the metal. This increases the surface area and provides a surface which makes it easier for gas bubbles to break away and rise to the surface. The electrodes are rinsed off with clean water and then coiled round to form the required shape and inserted into a length of plastic pipe as shown here:

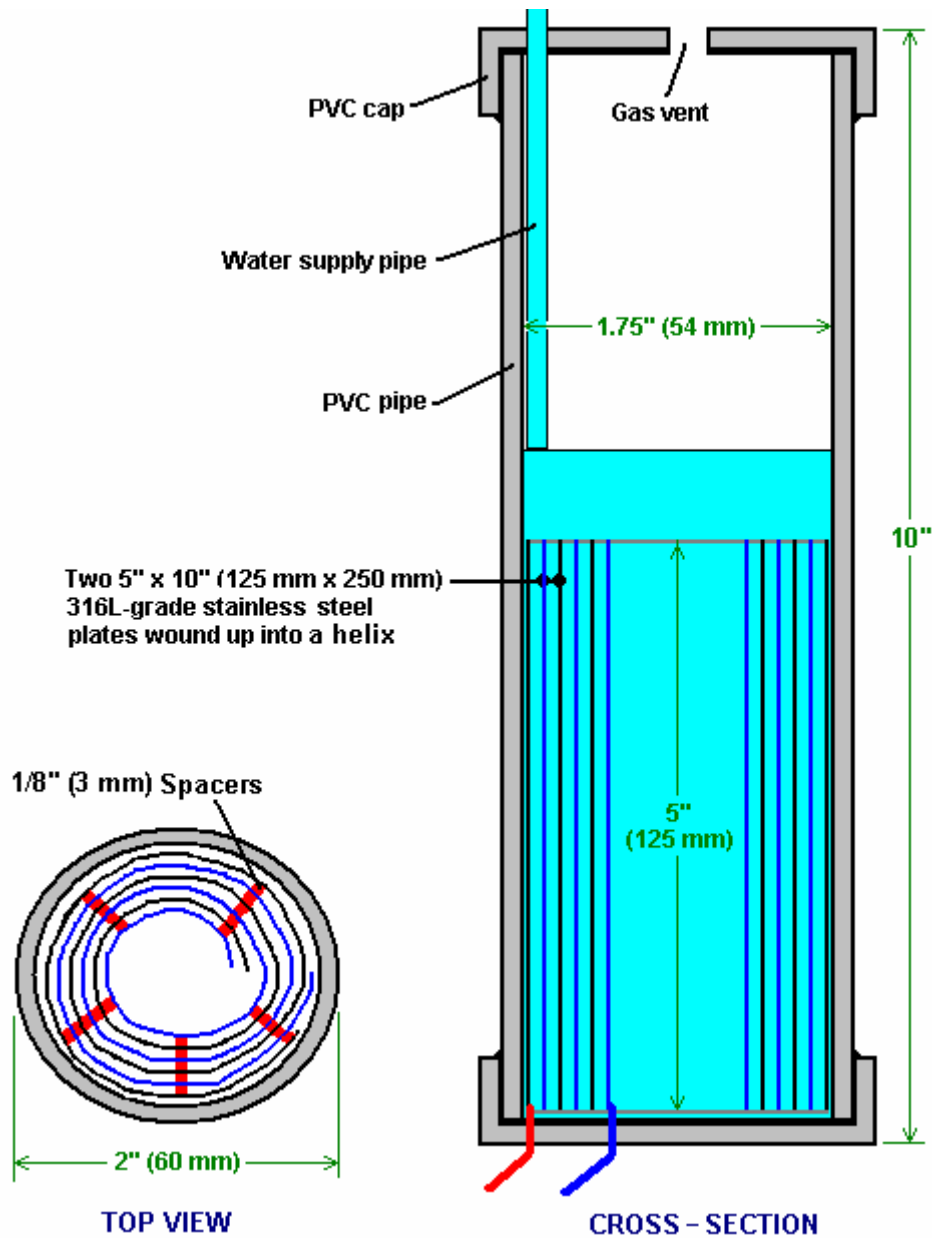

As the springy metal pushes outwards in an attempt to straighten up again, spacers are used to keep them evenly separated along their whole length by inserting 1/8" thick vertical spacer strips. The connections to the plates were made by drilling a hole in the corner of the plate, splitting the stranded wire, inserting the wire through the hole from both sides, turning it back on itself and making a wire-to-wire solder joint on both sides of the steel. The joint is then insulated with silicone.

An unusual feature of this design is that each of the electrode pairs is effectively a separate electrolyser in its own right as it is capped top and bottom, and effectively physically isolated from the other electrodes. The water feed comes through the top cap which has a hole drilled in it to allow the gas to escape. The electrical wires (AWG #12 / SWG 14) are fed through the base and sealed against leakage of electrolyte. Each of these units has some electrolyte stored above it, so there is no chance of any part of the electrode surface not being able to generate gas. There is also a large amount of freeboard to contain splashes and sloshing without any being able to escape from the container. The end caps are standard PVC caps available from the supplier of the PVC piping, as is the PVC glue used to seal them to the pipe.

Eight of these electrodes are placed in a simple electrolyser case and connected together in pairs as shown here:

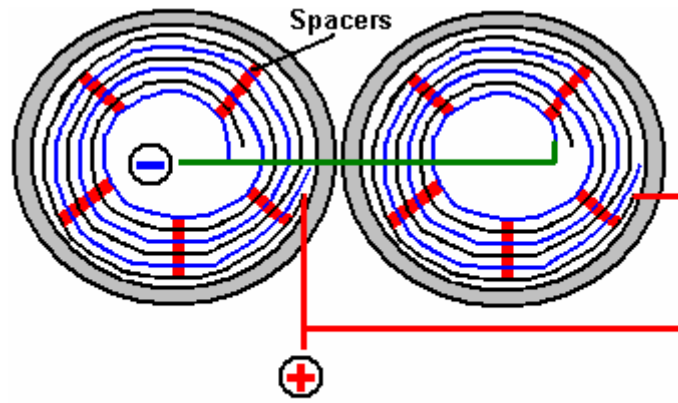

CELLS ARE WIRED IN PAIRS (Top View)

It is always difficult to make a good electrical connection to stainless steel plates if space is restricted as it is here. In this instance, the electrical wire is wrapped tightly through a drilled hole and then soldered and insulated. The soldering is only on the wire as solder will not attach to stainless steel.

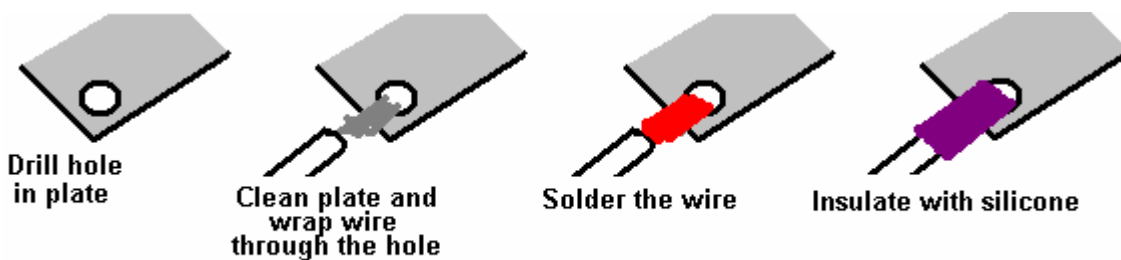

CONNECTING TO THE PLATES

Pairs of pipe-enclosed electrode spirals are then daisy-chained inside the electrolyzer as shown here:

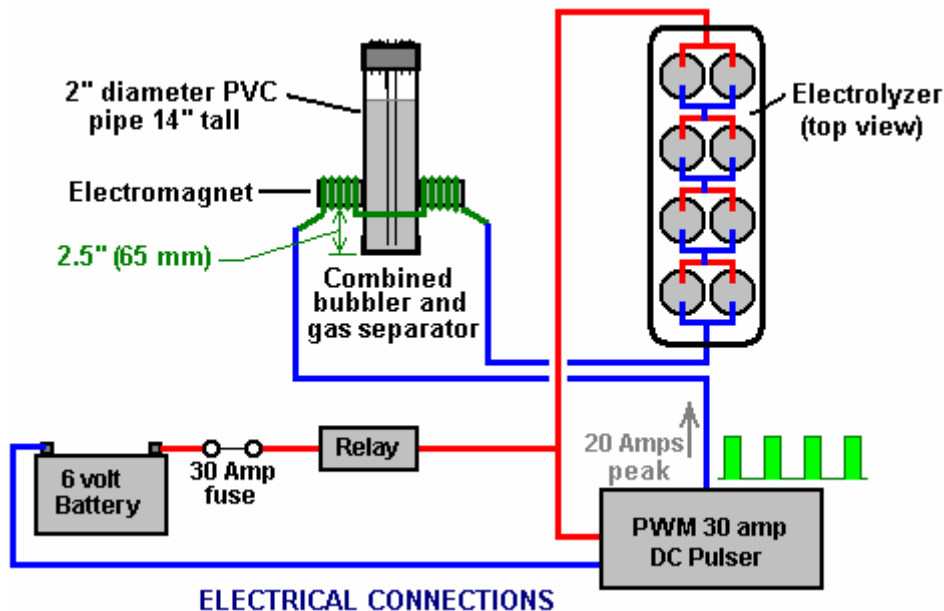

ELECTRICAL CONNECTIONS

Many years of experimentation and testing have shown that 316L-grade stainless steel is the most suitable material for electrodes, but surprisingly, stainless steel is not totally electrically conductive as you would expect. Each electrode causes a voltage drop of nearly half a volt, and so careful surface preparation, cleansing and conditioning are needed to get top performance from the electrodes. This process is described in detail later on.

The construction which Zach has used is very sensible, utilising readily available, low-cost PVC piping. The spiral electrodes are inside 2" diameter pipe and the bubbler is also 2" diameter PVC pipe. At this time, Zach only uses

one bubbler, but a second one is highly desirable, located between the storage tank and the engine and positioned as close to the engine as possible. This extra bubbler does two things, most importantly, it prevents the gas in the storage tank being ignited by a backfire caused by a valve sticking slightly open and secondly, it removes every last trace of potassium hydroxide fumes, protecting the life of the engine. This is a big gain for such a simple addition.

The gas storage tank is also made from PVC pipe, this time, 4 inch (100 mm) diameter, 14 inches (350 mm) long with standard end caps fixed in place with PVC glue as shown below. This is a compact and effective arrangement well suited for use on a motorcycle where spare space is not readily available. The majority of this extra equipment is mounted in the bike's panniers, which is a neat arrangement.

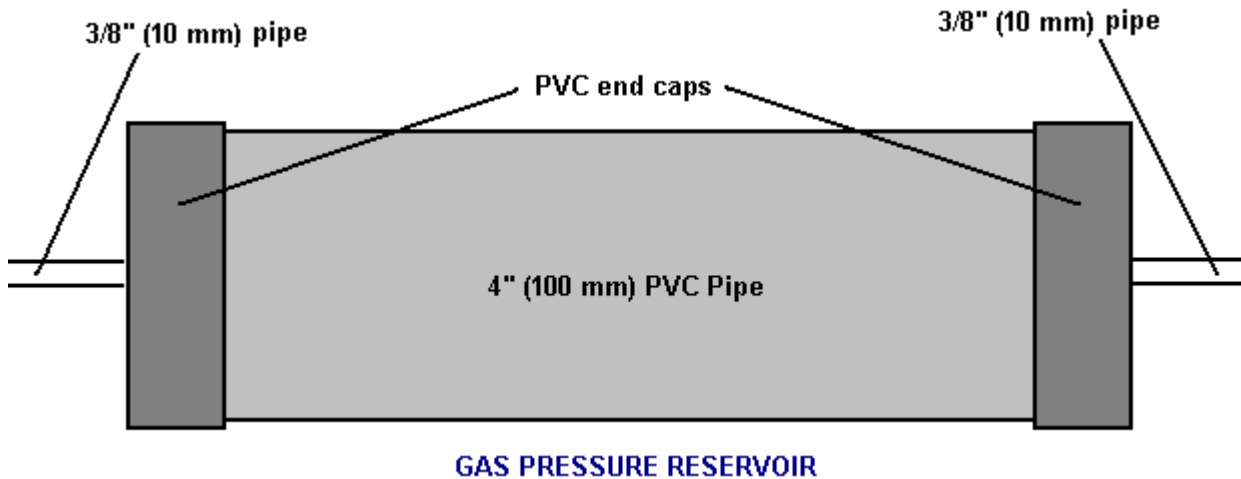

The electric drive to the electrolyser is from a Pulse Width Modulator (“DC Motor speed controller”) bought from the Hydrogen Garage:



http://stores.homestead.com/hydrogengarage/Categories.bok?category=ELECTRICAL+%2F+CIRCUITS&search_path=26438930&start=9&total=12

As this unit is rated at 15 Amps maximum, Zach added another 15 Amp rated FET transistor in parallel to the output stage to raise the current capacity to 30 Amps. A fuse protects against accidental short circuits and a relay is used to control when the electrolyser is to be producing gas. The connecting wire is AWG #12 (SWG 14) which has a maximum continuous current capacity of just under ten amps, so although the current peaks may be twenty amps, the average current is much lower than that.

Two electromagnets outside the bubbler, positioned 2.5 inches (65 mm) above the base, are connected as part of the electrical supply to the electrolyser, and these cause most of the oxygen and hydrogen bubbles to separate and exit the bubbler through different pipes. There is a divider across the bubbler to assist in keeping the gases from mixing again above the water surface. The bubbler also washes most of the potassium hydroxide fumes out of the gas as the bubbles rise to the surface, protecting the engine as these fumes have a very destructive effect on engines.

The objective with any hydroxy system is to have the minimum amount of gas between the bubbler and the engine in order to smother any ignition of the gas in the unlikely event of a backfire. In this system, the gas storage tank contains a very large amount of gas, though admittedly it is not full hydroxy gas thanks to the electromagnet separation system, but nevertheless, it would be most advisable to have a second bubbler

between the gas storage tank and the engine, positioned as close to the engine as possible. Hydroxy gas produces a very high-speed shock-wave when it is ignited so the bubbler needs to be of strong construction to withstand this. No pop-off bubbler cap or flash-back device acts fast enough to contain a hydroxy shock-wave, so make the bubbler housing strong to withstand the pressure wave.

Zach's electrolyser arrangement is like this:

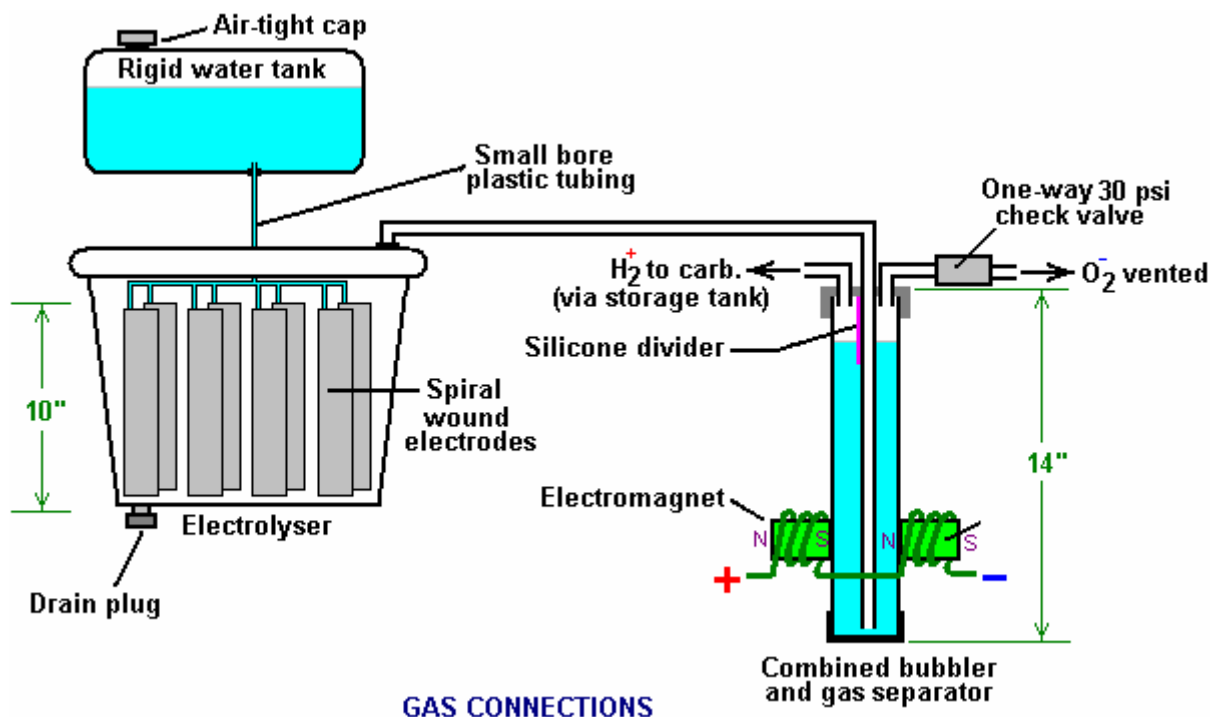

It must be realised that the water tank, electrolyser, bubbler/separator and hydrogen holding tank, all operate at thirty pounds per square inch. This means that each of these containers must be robust enough to withstand that pressure quite easily. It also means that the 30 psi one-way check valve on the oxygen venting pipe is an essential part of the design as well as being a safety feature. As a bubble of gas from the electrolyser escapes into the water tank every time a drop of water feeds to the electrolyser, the contents of the water tank above the water surface becomes a stronger and stronger mix of air and hydroxy. Consequently, it soon becomes an explosive mixture. It is common for static electricity to build up on a tank of this nature, so it will be very important to earth both the tank and its cap before removing the cap to fill the tank with water.

The electrolyser has a potassium hydroxide (KOH) solution in it. The electrolysis process produces a mixture of hydrogen, oxygen, dissolved gases (air) and potassium hydroxide fumes. The water in the bubbler washes out most of the potassium hydroxide fumes, becoming a more dilute form of the electrolyte as the system is used.

Potassium hydroxide is a true catalyst and while it promotes the electrolysis process, it does not get used up during electrolysis. The only loss is to the bubbler. Standard practice is to pour the contents of the bubbler into the electrolyser from time to time, filling the bubbler again with fresh water. Potassium hydroxide has been found to be the most effective catalyst for electrolysis but it has a very bad effect on the engine if it is allowed to enter it. The first bubbler is very effective in removing the potassium hydroxide fumes, but many people prefer to take the scrubbing process a step further by placing a second bubbler in the line, in this instance, between the hydrogen pressure tank and the engine. With two bubblers, absolutely no potassium hydroxide fumes reach the engine.

When running with hydroxy gas as the only fuel, it is essential to adjust the timing of the spark so that it occurs after Top Dead Centre. The timing on this bike is now set at 8 degrees after TDC.

If an engine is run without any fossil fuel at all, then timing adjustments need to be made. Hydrocarbon fuels have large molecules which do not burn fast enough to be efficient inside the cylinder of an engine. What happens is that for the first fraction of a second after the spark plug fires, the molecules inside the cylinder split up into much smaller particles, and then these smaller particles burn so fast that it can be described as an explosion:

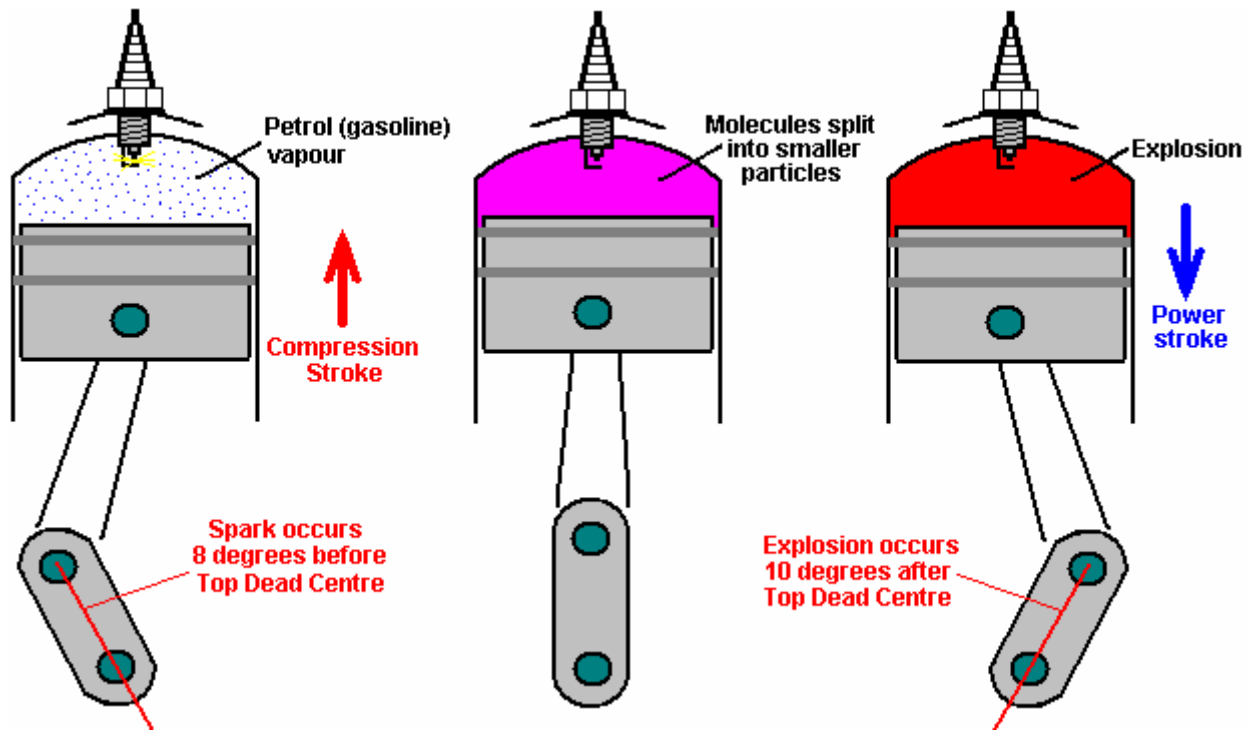

Because of the delay needed for the conversion of the hydrocarbon molecules to smaller particles, the spark is arranged to occur before the Top Dead Centre point. While the molecules are splitting up, the piston passes its highest point and the crankshaft is some degrees **past** Top Dead Centre before the driving pressure is placed on the head of the piston. This driving force then reinforces the clockwise rotation of the crankshaft shown in the diagram above and the motor runs smoothly.

That will **not** happen if hydroxy gas is substituted for the petrol vapour. Hydroxy gas has very small molecule sizes which do not need any kind of breaking down and which burn instantly with explosive force. The result is as shown here:

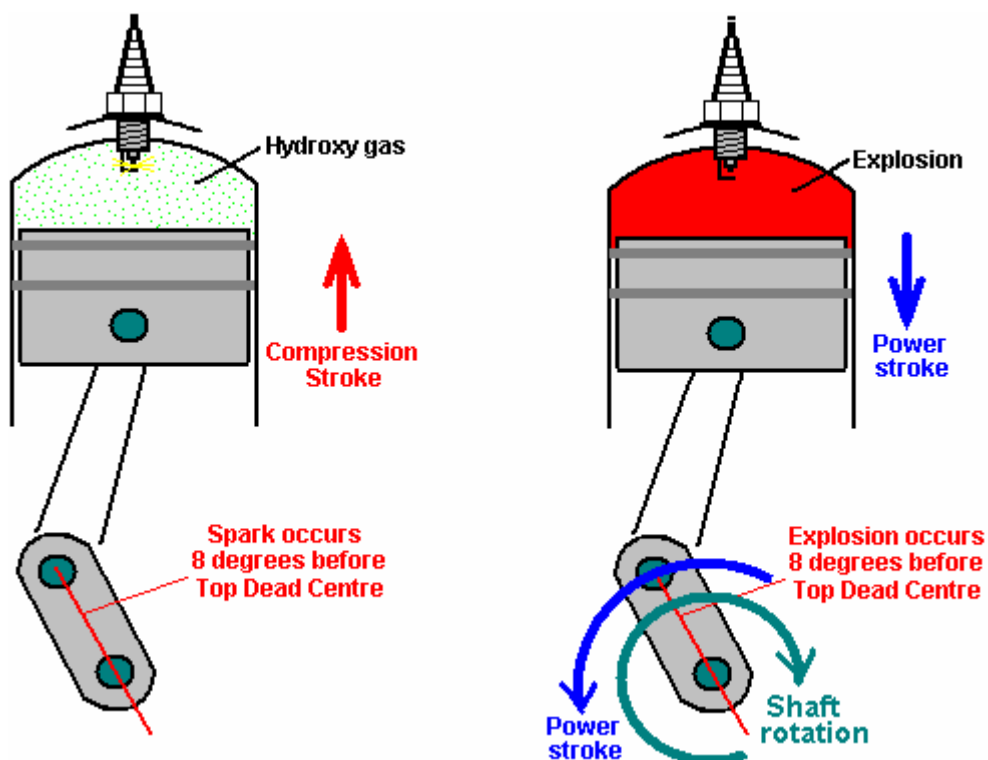

Here, the explosion is almost instantaneous and the explosion attempts to force the piston **downwards**. Unfortunately, the crankshaft is trying to drive the piston **upwards** past the Top Dead Centre ('TDC') point, so the explosion will not help the engine run. Instead, the explosion will stop the crankshaft rotating, overload the crankshaft and connecting rod and produce excessive pressure on the wall of the cylinder.

We do **not** want that to happen. The solution is to delay the spark until the piston has reached the position in its rotation where we want the explosion to take place - that is, in exactly the same place as it did when using petrol as a fuel.

In the example above, the spark would be retarded (delayed) from 8 degrees before TDC to 8 degrees after TDC, or 16 degrees overall. The spark is '**retarded**' because it needs to occur **later** in the rotation of the crankshaft. The amount of retardation may vary from engine to engine, but with hydroxy gas, the spark must never occur before TDC and it is preferable that the crankshaft has rotated some degrees past TDC so that most of the push from the piston goes to turn the crankshaft and as little as possible in compressing the crankshaft.

Waste Spark

One obvious application for a device such as this is to power a standard electrical generator and use part of the generator's output to power the electrolyser once the generator gets going. While this looks like a good idea, there are some practical issues which need to be dealt with.

Firstly, as detailed above, when running an internal combustion engine on hydroxy gas, it is essential to delay the spark until several degrees after Top Dead Centre. This may be difficult or impossible to do on some generators, so a careful examination of the engine details should be made before buying the generator. It is much easier to choose carefully than to be faced with a difficult timing adjustment on an engine which was never intended to have the timing adjusted.

Secondly, it is cheaper for the manufacturer to operate the spark from the output shaft of the engine rather than taking a linkage from the camshaft of a four-stroke engine. This generates a spark for every revolution of the output shaft. But, a four-stroke engine only needs a spark on every second revolution, so the extra spark is not needed and so is called a "waste" spark as it is wasted since there is no gas for it to ignite.

This waste spark is harmless when the engine is being run on fossil fuel which needs a spark timing before Top Dead Centre. The waste spark is most definitely **not** harmless when the timing is altered to some degrees after Top Dead Centre as needed by hydroxy gas operation. In this instance, when the waste spark occurs, the intake valve will be open creating a continuous path to the bubbler, and the waste spark **will** ignite the gas. It is absolutely vital to suppress any waste spark, and that is seldom an easy thing to do.

The spark timing needs to be mechanically linked to the position of the cam shaft, with either a contact on the cam shaft or a valve, or a 2:1 gearing down of the drive shaft as no electronic circuit can distinguish one particular pulse from a long row of identical pulses. It is easy to build an electronic circuit to suppress every second spark, but there is no way of knowing which spark to suppress. Pick the wrong spark and you instantly blow the gas supply. All the sparks look the same so you have a 50% chance of picking the wrong spark to suppress, so a contact or sensor on the cam shaft or a valve is essential whether or not an electronic circuit is used. An alternative is to take the timing from an external shaft, geared down to half the speed of the drive shaft as that is essentially a replication of the cam shaft.

So, when considering what generator to buy, you need to check the electrical power output, the noise level, the timing adjustment and if there is a waste spark and how easy it would be to avoid it.

Handling the electrolyte

This electrolyser design uses potassium hydroxide solution in the electrolyser itself and fresh water in the water tank as the potassium hydroxide is a true catalyst which assists the electrolysis process but does not get used up in the reaction. Potassium hydroxide is a strong caustic material and considerable care needs to be taken when preparing it. Here is the safety advice given by Bob Boyce, who is a most experienced and able builder of high-efficiency electrolysers and his instructions should be followed carefully in every respect when handling potassium hydroxide and preparing stainless steel for use in an electrolyser:

Mixing Potassium Hydroxide Solution

Potassium hydroxide is also known as "caustic potash" and it is highly caustic. Consequently, it needs to be handled carefully and kept away from contact with skin, and even more importantly, eyes. If any splashes come in contact with you, it is very important indeed that the affected area be immediately rinsed off with large amounts of running water and if necessary, the use of vinegar which is acidic.

This electrolyser design requires you to make up a weak solution of potassium hydroxide. This is done by adding small amounts of the potassium hydroxide to distilled water held in a container. The container must not be glass as most glass is not high enough quality to be a suitable material in which to mix the electrolyte.

Potassium hydroxide, also called KOH or "Caustic Potash", can be bought in small quantities from soap making supply outlets such as:

<http://www.essentialdepot.com/servlet/the-13/2-lbs-Potassium-Hydroxide/Detail>

<http://www.organic-creations.com/servlet/the-653/caustic-potassium-hydroxide-KOH/Detail>

<http://www.aaa-chemicals.com/pohy2posa.html> or

<http://www.nuscentcandle.com/PHFLAKES.html>.

While Potassium hydroxide is the very best electrolyte, it needs to be treated with care:

Always store it in a sturdy, air-tight container which is clearly labelled "DANGER! - Potassium Hydroxide". Keep the container in a safe place, where it can't be reached by children, pets or people who won't take any notice of the label. If your supply of KOH is delivered in a strong plastic bag, then once you open the bag, you should transfer all its contents to sturdy, air-tight, plastic storage containers, which you can open and close without risking spilling the contents. Hardware stores sell large plastic buckets with air tight lids that can be used for this purpose.

When working with dry KOH flakes or granules, wear safety goggles, rubber gloves, a long sleeved shirt, socks and long trousers. Also, don't wear your favourite clothes when handling KOH solution as it is not the best thing to get on clothes. It is also no harm to wear a face mask which covers your mouth and nose. If you are mixing solid KOH with water, always add the KOH to the water, and not the other way round, and use a plastic container for the mixing, preferably one which has double the capacity of the finished mixture. The mixing should be done in a well-ventilated area which is not draughty as air currents can blow the dry KOH around.

When mixing the electrolyte, **never** use warm water. The water should be cool because the chemical reaction between the water and the KOH generates a good deal of heat. If possible, place the mixing container in a larger container filled with cold water, as that will help to keep the temperature down, and if your mixture should "boil over" it will contain the spillage. Add only a small amount of KOH at a time, stirring continuously, and if you stop stirring for any reason, put the lids back on all containers.

If, in spite of all precautions, you get some KOH solution on your skin, wash it off with plenty of running cold water and apply some vinegar to the skin. Vinegar is acidic, and will help balance out the alkalinity of the KOH. You can use lemon juice if you don't have vinegar to hand - but it is always recommended to keep a bottle of vinegar handy.

Plate Cleansing and Conditioning

Experience has shown that the best material for use as electrodes in this electrolyser design is 317L-grade stainless steel, but cost considerations make 316L-grade the material chosen by most people. The preparation of the plates is one of the most important steps in producing an electrolyser which works well. This is a long task, but it is vital that it is not skimped or hurried in any way. Surprisingly, brand new shiny stainless steel is not particularly suitable for use in an electrolyser and it needs to receive careful treatment and preparation before it will produce the expected level of gas output.

The first step is to treat both surfaces of every plate to encourage gas bubbles to break away from the surface of the plate. This could be done by grit blasting, but if that method is chosen, great care must be taken that the grit used does not contaminate the plates. Stainless steel plates are not cheap and if you get grit blasting wrong, then the plates will be useless as far as electrolysis is concerned. A safe method which Bob much prefers is to score the plate surface with coarse sandpaper. This is done in two different directions to produce a cross-hatch pattern. This produces microscopic sharp peaks and valleys on the surface of the plate and those sharp points and ridges are ideal for helping bubbles to form and break free of the plate.

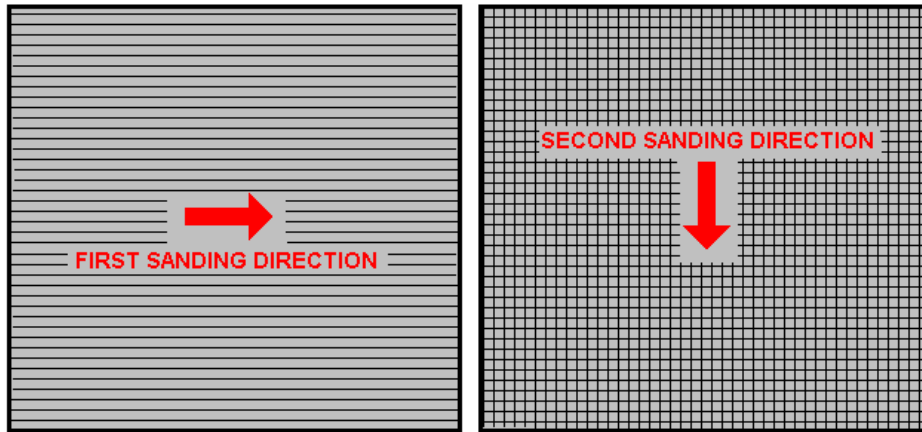

Bob Boyce uses a specially widened 48-inch belt sander which is good for preparing the plates using 60 or 80 grit. However, most people don't have this equipment and do the sanding by hand. Bob stresses that when doing hand sanding the sandpaper is drawn across the plates in **one** direction only and not backwards and forwards, as the backwards stroke always destroys the perfectly good ridges created on the forward stroke. Also, you only need two strokes in one direction before turning the plate through ninety degrees and completing the sanding of that face of the plate with just two more strokes (again, with **no backstroke**). Most people want to sand the plates far too much and if overdone to a major degree, that can reduce the plate thickness and cause electrolyte leakage through the slots around the plates. So, to say it again, to sand one face of a plate, use just two strokes in one direction, turn the plate through ninety degrees and finish that face with just two more strokes, both in the same direction.

Always wear rubber gloves when handling the plates to avoid getting finger marks on the plates. Wearing these gloves is very important as the plates must be kept as clean and as grease-free as possible, ready for the next stages of their preparation.

Any particles created by the sanding process should now be washed off the plates. This can be done with clean tap water (not city water though, due to all the chlorine and other chemicals added), but only use distilled water for the final rinse.

Following all the safety precautions for mixing electrolyte (in the Bob Boyce section), prepare a 5% to 10% NaOH sodium hydroxide / lye solution (50 grams of NaOH in 950 cc water, to 100 g of NaOH in 900 cc of water) and let it cool down. Never handle the plates with your bare hands, but always use clean rubber gloves. Wind the plate material into its spiral shape with two layers of 1/8" (3 mm) spacing material such as leather between the plates and projecting well beyond one end. Wind the plates into the spiral shape (strictly speaking, a helix shape) and slide them into a cut length of the plastic tube. The springy plates expand to press against the inside of the plastic pipe. Pull the spacing material out slightly and start inserting 1/8" x 1/8" five inch long spacers between the plates. Keep on pulling the spacing sheets out and pushing the spacing strips in until they are inserted the full length of the plates.

Fill the electrolyser with the NaOH solution until the plates are covered. A voltage is now applied across the whole set of plates by attaching the leads to the outermost two plates. This voltage should be at least 2 volts per cell, but it should not exceed 2.5 volts per cell - for four pairs of spirals, this is 8 to 10 volts. Maintain this voltage across the set of plates for several hours at a time. The current is likely to be 4 amps or more. As this process continues, the boiling action will loosen particles from the pores and surfaces of the metal. This process produces hydroxy gas, so it is very important that the gas is not allowed to collect anywhere indoors (such as on ceilings).

After several hours, disconnect the electrical supply and pour the electrolyte solution into a container. Rinse out the cells thoroughly with distilled water. Filter the dilute NaOH solution through paper towels or coffee filters to remove the particles. Pour the dilute solution back into the electrolyser and repeat this cleaning process. You may have to repeat the electrolysis and rinsing process many times before the plates stop putting out particles into the solution. If you wish, you can use a new NaOH solution each time you cleanse, but please realise that you can go through a lot of solution just in this cleaning stage if you choose to do it that way. When cleansing is finished (typically 3 days of cleansing), do a final rinse with clean distilled water.

Now, with thoroughly clean plates, the final conditioning process can be undertaken. Using the same concentration of solution as in cleansing, fill the electrolyser with this dilute solution. Apply about 2 volts per cell and allow the unit to run. Remember that very good ventilation is essential during this process. If the current draw is fairly stable, continue with this conditioning phase continuously for two to three days, adding distilled water to replace what is consumed. If the solution changes colour or develops a layer of crud on the surface of the

electrolyte, then the cell stack needs more cleansing stages. After two to three days of run time, pour out the dilute NaOH solution and rinse out the electrolyser thoroughly with distilled water.

This cleansing and conditioning process makes a spectacular difference to the volume of gas produced for any given current flow through the electrolyser. It is perfectly possible to build an electronics drive unit suitable for use with this electrolyser. Here is a well-tested design:

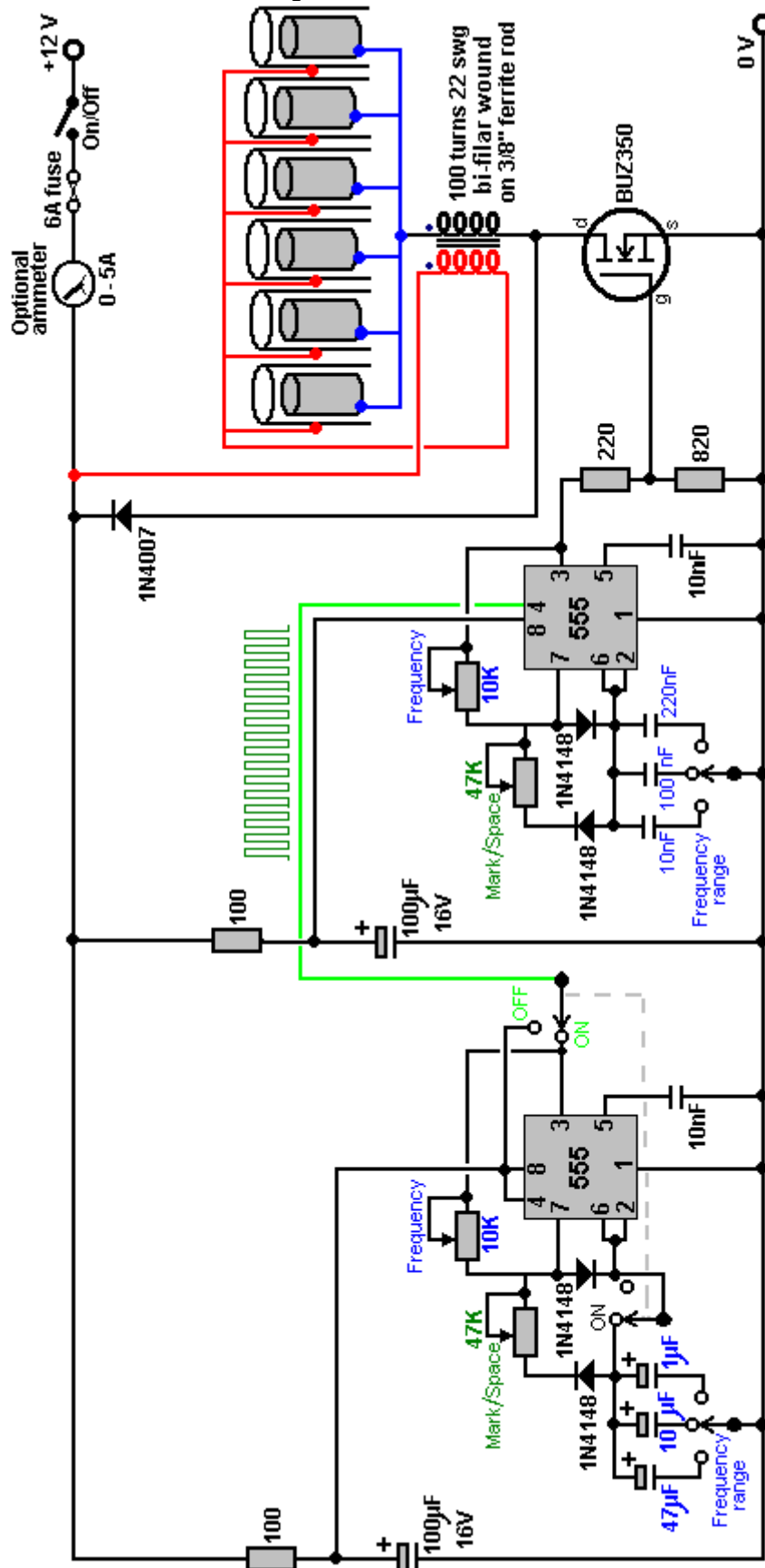

This circuit design is taken from Dave Lawton's replication of Stan Meyer's Water Fuel Cell. The circuit is shown below. More detail is given later on in this chapter. There is no call for the bi-filar wound coils each side of the electrolyser in this design, but it might be interesting to see what effect is produced if they were introduced as they generate very short, very sharp voltage spikes of over a thousand volts, which tend to draw in additional power from the immediate environment.

This circuit is designed to run off twelve volts and while it would probably function well at the nominal six volts of a motorcycle electrics (about 7.3 volts with the engine running), it is likely that a twelve volt version of this electrolyser design will be required for automotive use. In that case, the electrolyser housing would probably become:

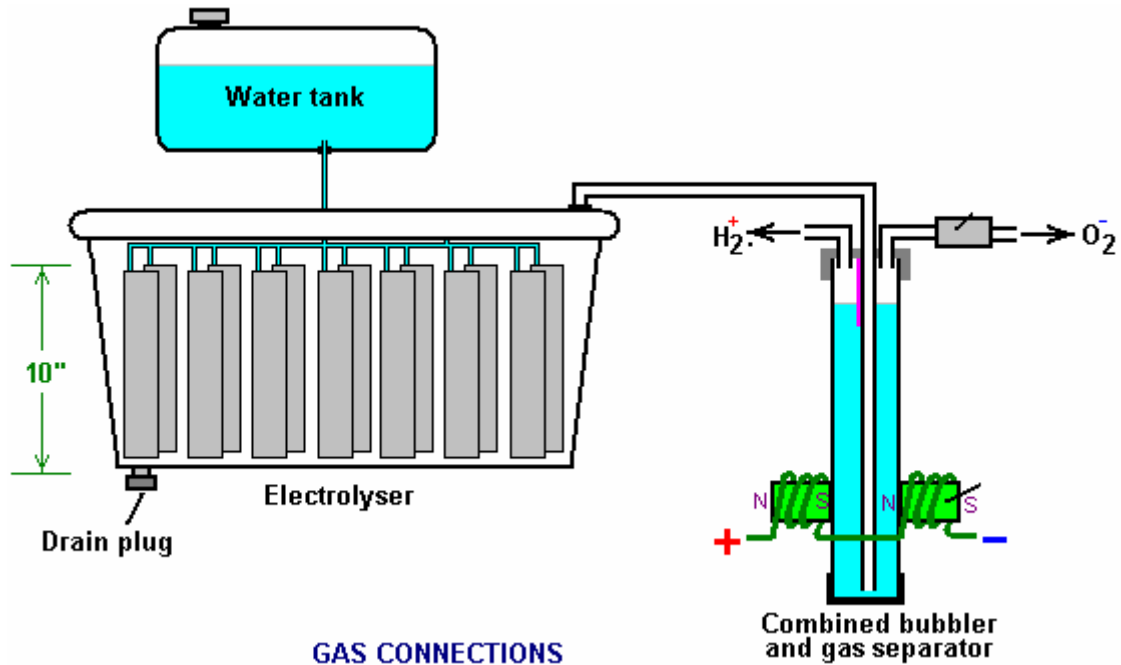

It is possible that seven sets of three or four spirals would be used for larger engines with their 13.8 volt electric systems. Ideally, setting the frequency to the resonant frequency of the particular electrolyser build being used, is likely to enhance the gas output. For this, the adjustable frequency PWM unit shown here is likely to be suitable as it has worked well with other designs.

Zach uses the very simple mechanism of allowing excess gas to be vented via the oxygen valve if gas production exceeds the requirements of the engine. When operating on a twelve volt system it might be more convenient to use a standard pressure switch which opens an electrical connection when the gas pressure rises above the value for that switch:



The pressure switch just mounts on one of the end caps of the pressure tank and the switch electrical connection is placed between the relay and the electrolyser. If the gas pressure hits its maximum value of 30 psi. then the switch opens, stopping electrolysis until the pressure drops again:

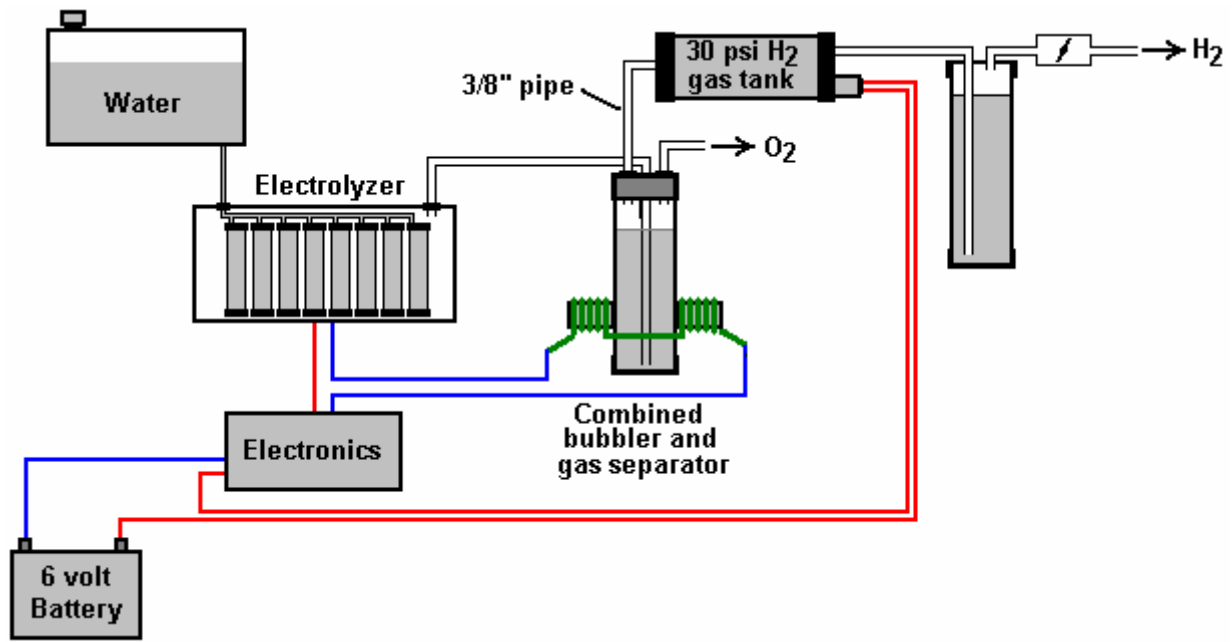

● = Track cut on underside of the board

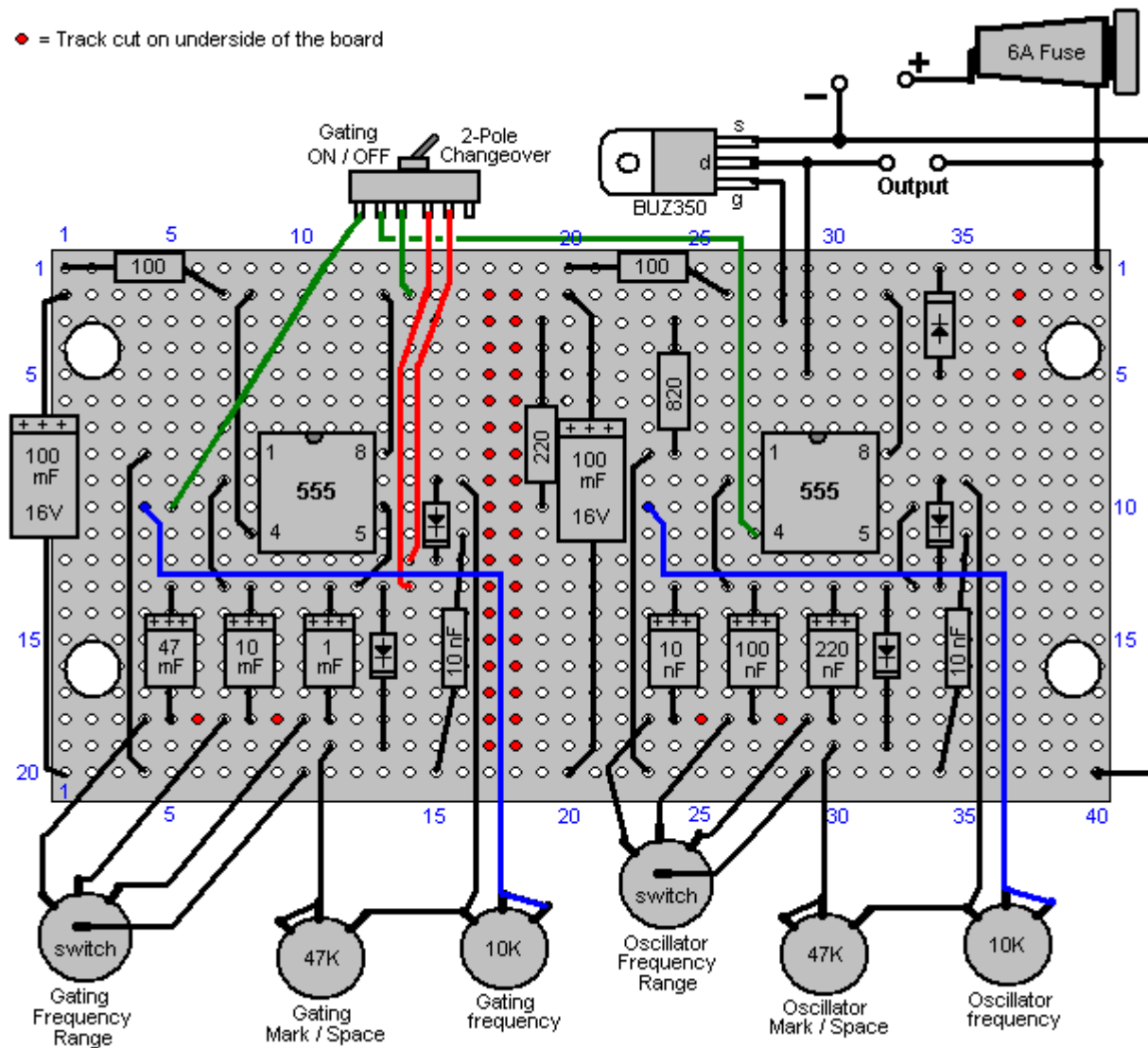

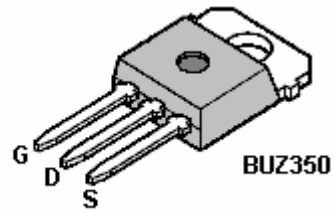
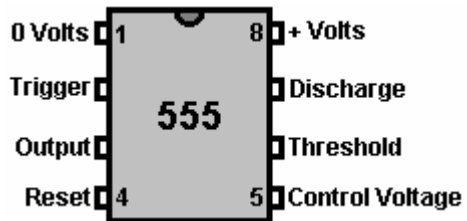

The underside of the strip-board is shown here:

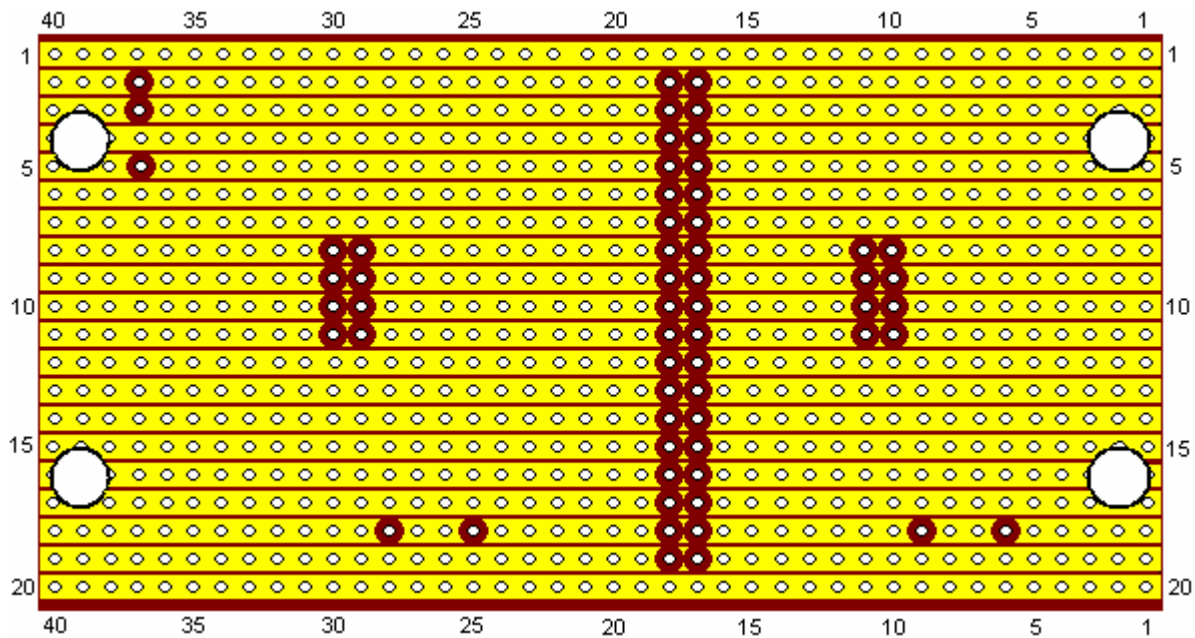

The ammeter shown here is not really necessary and can be omitted.

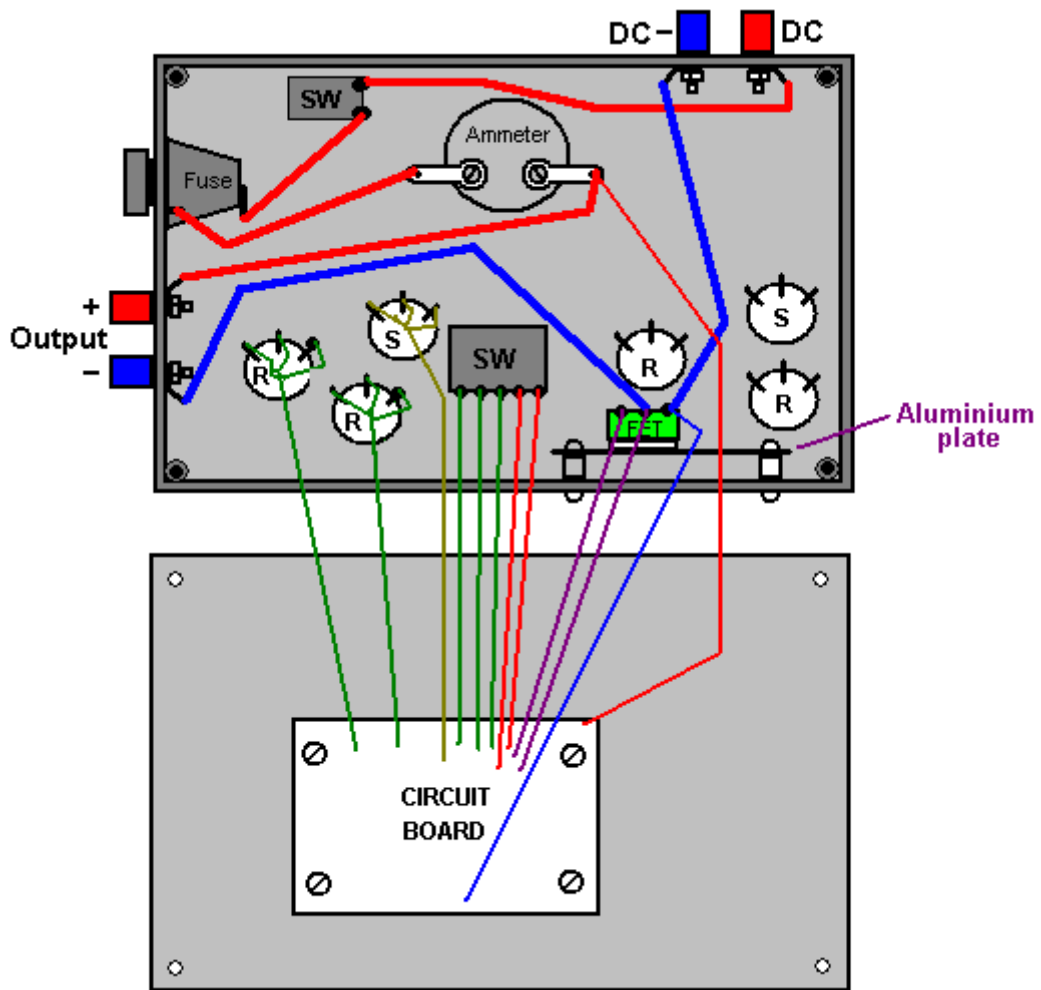

Component	Quantity	Description	Comment
100 ohm resistors 0.25 watt	2	Bands: Brown, Black, Brown	
220 ohm resistor 0.25 watt	1	Bands: Red, Red, Brown	
820 ohm resistor 0.25 watt	1	Bands: Gray, Red, Brown	
100 mF 16V capacitor	2	Electrolytic	
47mF 16V capacitor	1	Electrolytic	
10 mF 16V capacitor	1	Electrolytic	
1 mF 16 V capacitor	1	Electrolytic	
220 nF capacitor (0.22 mF)	1	Ceramic or polyester	
100 nF capacitor (0.1 mF)	1	Ceramic or polyester	
10 nF capacitor (0.01 mF)	3	Ceramic or polyester	
1N4148 diodes	4		
1N4007 diode	1		FET protection
NE555 timer chip	2		
BUZ350 MOSFET	1	Or any 200V 20A n-channel MOSFET	
47K variable resistors	2	Standard carbon track	Could be screw track
10K variable resistors	2	Standard carbon track	Could be screw track
4-pole, 3-way switches	2	Wafer type	Frequency range
1-pole changeover switch	1	Toggle type, possibly sub-miniature	Any style will do
1-pole 1-throw switch	1	Toggle type rated at 10 amps	Overall ON / OFF switch
Fuse holder	1	Enclosed type or a 6A circuit breaker	Short-circuit protection
Veroboard	1	20 strips, 40 holes, 0.1 inch matrix	Parallel copper strips
8-pin DIL IC sockets	2	Black plastic, high or low profile	Protects the 555 ICs
Wire terminals	4	Ideally two red and two black	Power lead connectors
Plastic box	1	Injection moulded with screw-down lid	
Mounting nuts, bolts and pillars	8	Hardware for 8 insulated pillar mounts	For board and heatsink
Aluminium sheet	1	About 4 inch x 2 inch	MOSFET heatsink
Rubber or plastic feet	4	Any small adhesive feet	Underside of case
Knobs for variable resistors etc.	6	1/4 inch shaft, large diameter	Marked skirt variety
Ammeter	1	Optional item, 0 to 5A or similar	
Ferrite rod 1-inch long or longer	1	For construction of the inductors	bi-filar wound
22 SWG (21 AWG) wire	1 reel	Enamelled copper wire, 2 oz. reel	
Sundry connecting wire	4 m	Various sizes	

Caution: This electrolyser is not a toy. If you make and use one of these, you do so entirely at your own risk. Neither the designer of the electrolyser, the author of this document or the provider of the internet display are in any way liable should you suffer any loss or damage through your own actions. While it is believed to be entirely safe to make and use an electrolyser of this design, provided that the safety instructions shown below are followed, it is stressed that the responsibility is yours and yours alone.

An electrolyser should not be considered as an isolated device. You need to remember that both electrical and gas safety devices are an essential part of any such installation. The electrical safety devices are a circuit-breaker (as used by any electrician when wiring a house) to protect against accidental short-circuits, and a relay to make sure that the booster does not operate when the engine is not running:

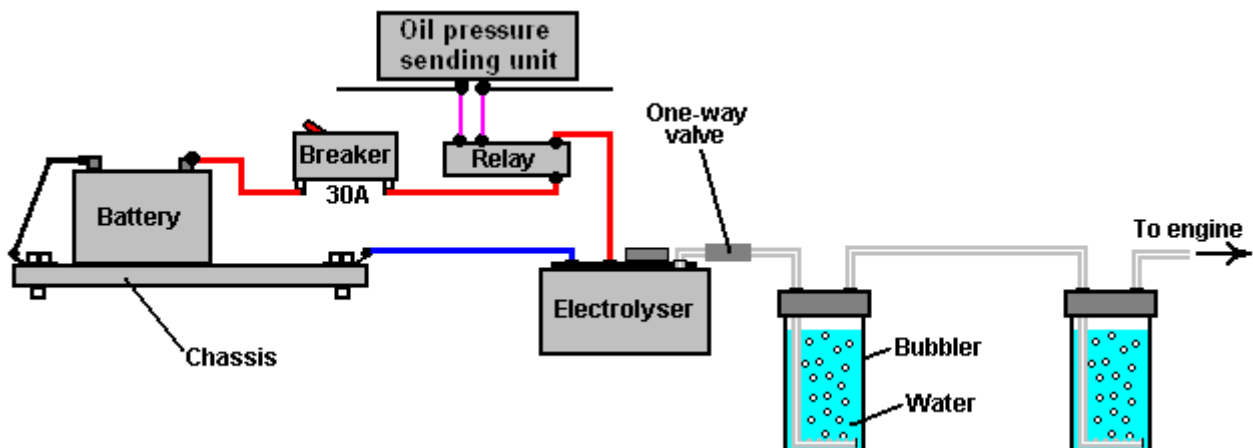

The bubblers are there to wash every last trace of electrolyte fumes out of the hydroxy gas being fed to the engine, and to protect against a flash-back caused by the engine misfiring due to a valve sticking. There is more information on these things in chapter 10 on the <http://www.free-energy-info.com> website.

Patrick Kelly

engpjk@gmail.com

<http://www.free-energy-info.com>

<http://www.free-energy-devices.com>